

EFFECTIVE: July 1, 2015

SUPERSEDES: January 8, 2010

1760 RPM MODEL 3007

JOB \_\_\_\_\_ ENGINEER \_\_\_\_\_

CONTRACTOR \_\_\_\_\_ REP. \_\_\_\_\_

ITEM NO.	MODEL NO.	IMPELLER DIA.	G.P.M.	HEAD/FT.	H.P.	ELEC. CHAR.
----------	-----------	---------------	--------	----------	------	-------------

NSF 61 Certified

Yes  No

WEIGHT \_\_\_\_\_ PUMP/MOTOR \_\_\_\_\_

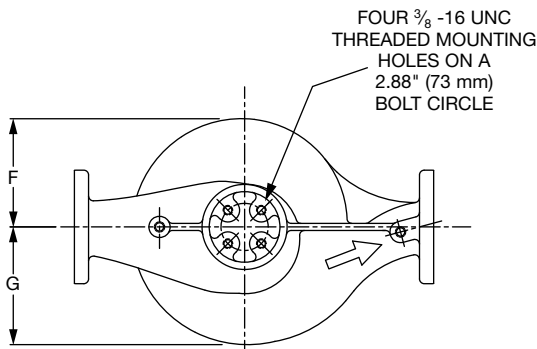
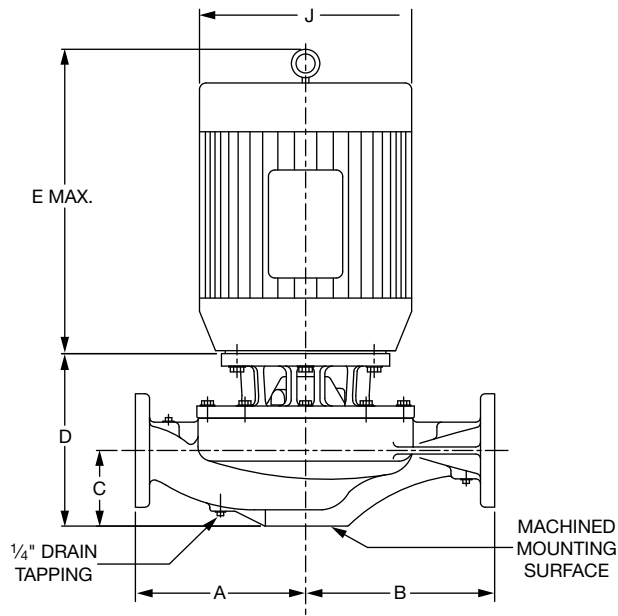

### PUMP WITH OPTIONAL SUPPORT STAND

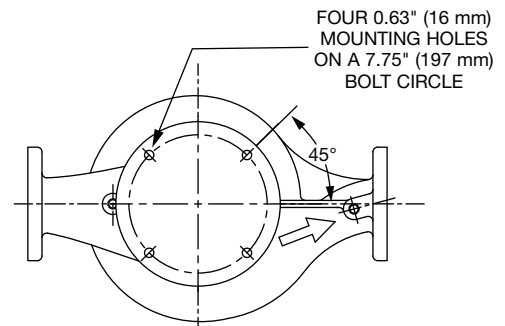
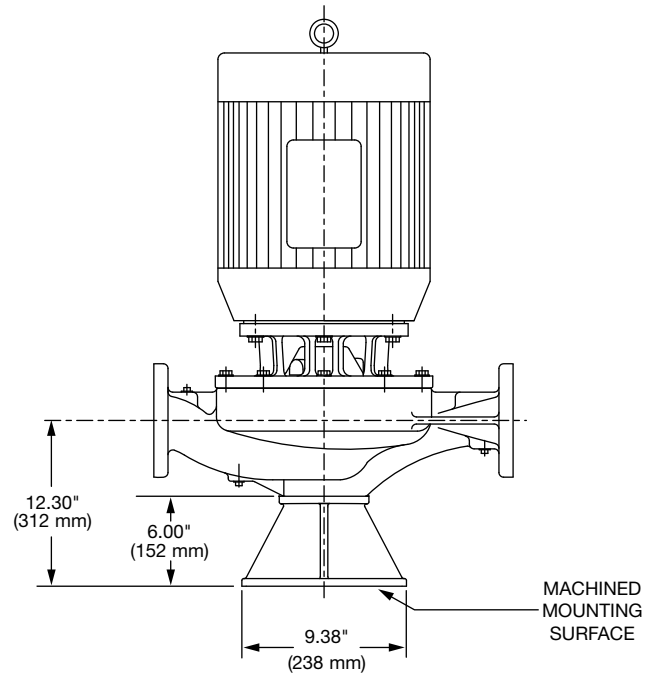

### DIMENSIONS

\*A & B Dimensions apply for all pump sizes.

Model No.	Conn.	Motor Frame	HP 1760 RPM	Flange Size ASA	A*	B*	C	D	E MAX	F	G	H	J DIA
3007	3 x 3 (76 x 76)	145JM	2	3 (76)	10.00 (254) if ANSI Class 125	10.00 (254) if ANSI Class 125	6.30 (160)	10.53 (267)	13.43 (341)	5.29 (134)	6.31 (160)	0.25 (6)	6.62 (168)
		182JM	3					10.53 (267)	13.94 (354)				7.88 (200)
		184JM	5					10.53 (267)	15.58 (396)				7.88 (200)
		213JM	7.5					10.53 (267)	16.68 (424)				9.56 (234)

English dimensions are in inches. Metric dimensions are in millimeters. Metric data is presented in ( ).  
Do not use for construction purposes unless certified.

**MATERIALS OF CONSTRUCTION**

Item	BRONZE FITTED		ALL IRON		NSF 61	
	Standard Pump Construction	Optional	Standard	Optional	Standard	Optional
Casing	Cast Iron ASTM A48 Class 30A	N/A	Cast Iron ASTM A48 Class 30A	N/A	Cast Iron ASTM A48 Class 30A	N/A
Impeller	Bronze ASTM B584-836	CF	Cast Iron ASTM A48 Class 30A	CF	St. Steel AISI 416 ASTM A582	CF
Wear Ring	None	Bronze ASTM B584-932 SAE660	None	N/A	None	Bronze ASTM B584-932 SAE660
Shaft	St. Steel AISI 416 ASTM A582	N/A	St. Steel AISI 416 ASTM A582	N/A	St. Steel AISI 416 ASTM A582	N/A
Coupling	Aluminum Alloy 6061-T6	N/A	Aluminum Alloy 6061-T6	N/A	Aluminum Alloy 6061-T6	N/A
Mechanical Seal	Ceramic / EPT	Tungsten Carbide / Silicon-Carbide/Carbon/EPT	Ceramic / EPT	Tungsten Carbide / Silicon-Carbide/Carbon/EPT	Ceramic / EPT	Tungsten Carbide / Silicon-Carbide/Carbon/EPT
Seal Flush Line	Copper	CF	Stainless Steel	CF	Copper	CF
Support Stand	N/A	Ductile Iron ASTM A536-84 Grade: 65-45-12	N/A	Ductile Iron ASTM A536-84 Grade: 65-45-12	N/A	Ductile Iron ASTM A536-84 Grade: 65-45-12

**OPERATING SPECIFICATIONS**

	Standard		Optional
Flange	ANSI Class 125	ANSI Class 250	
Pressure	175 PSIG* (1210 KPA)	300 PSIG** (2070 KPA)	CF
Temperature	250°F (120°C)	250°F (120°C)	CF

Motors: All NEMA Standard (T Frame)  
 \* In accordance with ANSI Standard B16.1 Class 125  
 \*\* In accordance with ANSI Standard B16.1 Class 250 Dim.

**MAXIMUM ASSEMBLY WEIGHT**

Motor Frame	Weight without Optional Stand Lbs (Kg)	Weight with Optional Stand Lbs (Kg)
143JM - 145JM	150 (68)	169 (77)
182JM - 184JM	184 (83)	203 (92)
213JM - 215JM	246 (112)	265 (120)

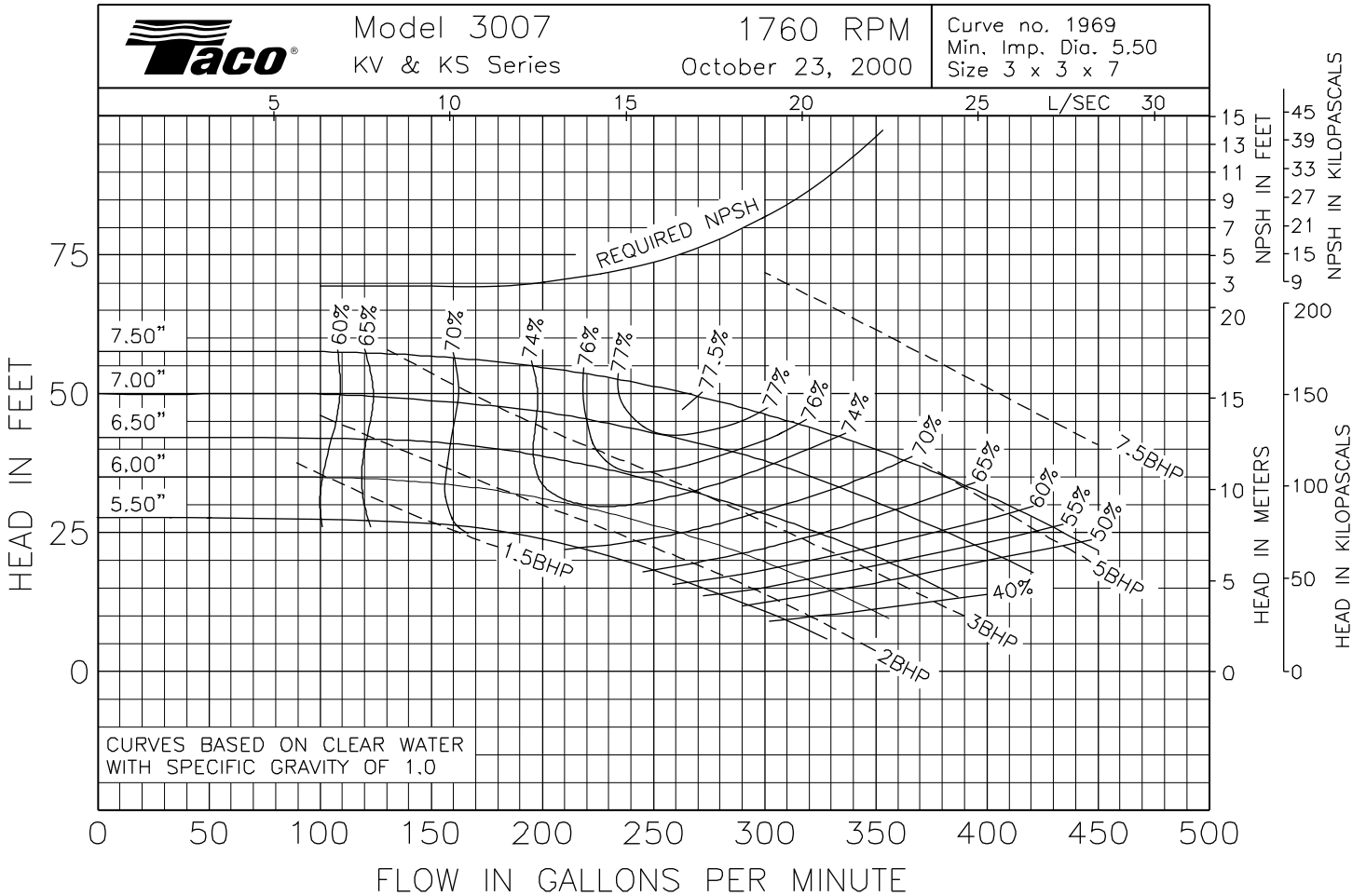

Comments \_\_\_\_\_

**Taco Comfort Solutions™** A Taco Group Company

Taco, Inc., 1160 Cranston Street, Cranston, RI 02920 | Tel: (401) 942-8000 | FAX: (401) 942-2360

Taco (Canada), Ltd., 8450 Lawson Road, Suite #3, Milton, Ontario L9T 0J8 | Tel: (905) 564-9422 | FAX: (905) 564-9436

Visit our web site: [www.TacoComfort.com](http://www.TacoComfort.com) | Printed in USA | ©2015 Taco, Inc.

