



Submittal Data Information

FI Series Pumps

301-2403

EFFECTIVE: JULY 1, 2015

SUPERSEDES: MARCH 1, 2013

1760 RPM MODEL 1209C

JOB _____ ENGINEER _____

CONTRACTOR _____ REP. _____

ITEM NO.	MODEL NO.	IMPELLER DIA.	G.P.M.	HEAD/FT.	H.P.	ELEC. CHAR.
----------	-----------	---------------	--------	----------	------	-------------

NSF 61 Certified

Yes No

WEIGHT _____ PUMP/MOTOR _____

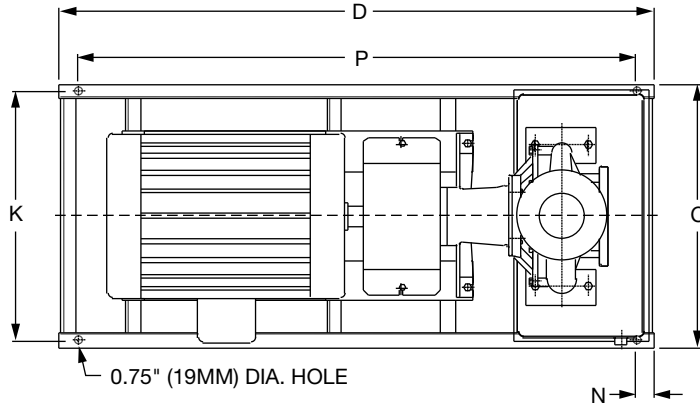

OPERATING SPECIFICATIONS

	Standard	Optional
Flange	ANSI Class 125	ANSI Class 250
Pressure	175 PSIG* (1210 KPA)	300 PSIG** (2070 KPA)
Temperature	250°F (120°C)	250°F (120°C)

Motors: All NEMA Standard (T Frame)
 * In accordance with ANSI Standard B16.1 Class 125
 ** In accordance with ANSI Standard B16.1 Class 250 Dim.

MAXIMUM ASSEMBLY WEIGHT

Motor Frame	Weight Lbs (Kg)
143T - 145T	287 (130)
182T - 184T	407 (185)

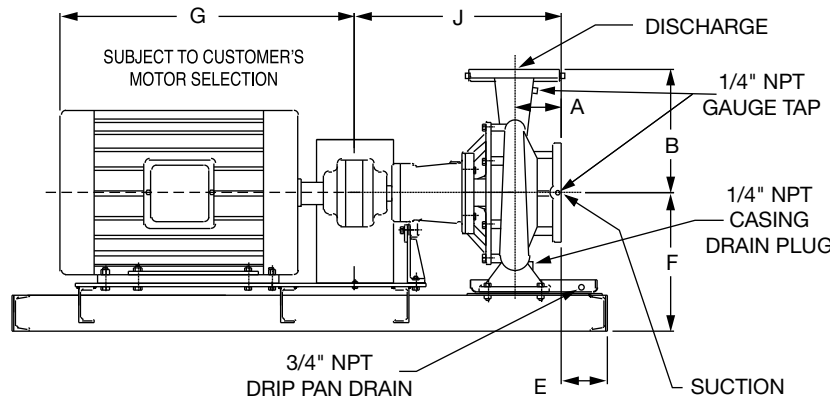

DIMENSIONS

50 Cycle Performance Curves attached when applicable.

Model No. Flange Size (Suction x Discharge)	Motor Frame	HP 1760 (RPM)	A		B		C	D	E		F	G	J		K	N	P
			ANSI Class 125	ANSI Class 250	ANSI Class 125	ANSI Class 250			ANSI Class 125	ANSI Class 250			ANSI Class 125	ANSI Class 250			
1209C 1 1/2 x 1 1/4 (38 x 32)	145T	1.5	3.50 (89)	3.75 (95)	9.10 (231)	9.36 (238)	17.18 (436)	40.0 (1016)	2.53 (64)	2.28 (58)	11.28 (287)	13.00 (330)	17.05 (433)	17.30 (439)	15.68 (398)	2.00 (51)	36.0 (914)
		2										15.38 (391)					
	182T	3										16.56 (421)					
	184T	5															

English dimensions are in inches. Metric dimensions are in millimeters. Metric data is presented in (). Do not use for construction purposes unless certified.

MATERIALS OF CONSTRUCTION

Item	BRONZE FITTED		ALL IRON		NSF 61	
	Standard Pump Construction	Optional	Standard	Optional	Standard	Optional
Casing	Cast Iron ASTM A48 Class 30A	N/A	Cast Iron ASTM A48 Class 30A	N/A	Cast Iron ASTM A48 Class 30A	N/A
Impeller	Bronze ASTM B584-836	CF	Cast Iron ASTM A48 Class 30A	CF	St. Steel AISI 416 ASTM A582	CF
Wear Ring	None	Bronze ASTM B584-932 SAE660	None	N/A	None	Bronze ASTM B584-932 SAE660
Shaft	St. Steel AISI 416 ASTM A582	N/A	St. Steel AISI 416 ASTM A582	N/A	St. Steel AISI 416 ASTM A582	N/A
Coupling	Aluminum Alloy 6061-T6	N/A	Aluminum Alloy 6061-T6	N/A	Aluminum Alloy 6061-T6	N/A
Mechanical Seal	Ceramic / EPT	Tungsten Carbide / Silicon-Carbide/Carbon/EPT	Ceramic / EPT	Tungsten Carbide / Silicon-Carbide/Carbon/EPT	Ceramic / EPT	Tungsten Carbide / Silicon-Carbide/Carbon/EPT
Seal Flush Line	Copper	CF	Stainless Steel	CF	Copper	CF
Support Stand	N/A	Ductile Iron ASTM A536-84 Grade: 65-45-12	N/A	Ductile Iron ASTM A536-84 Grade: 65-45-12	N/A	Ductile Iron ASTM A536-84 Grade: 65-45-12

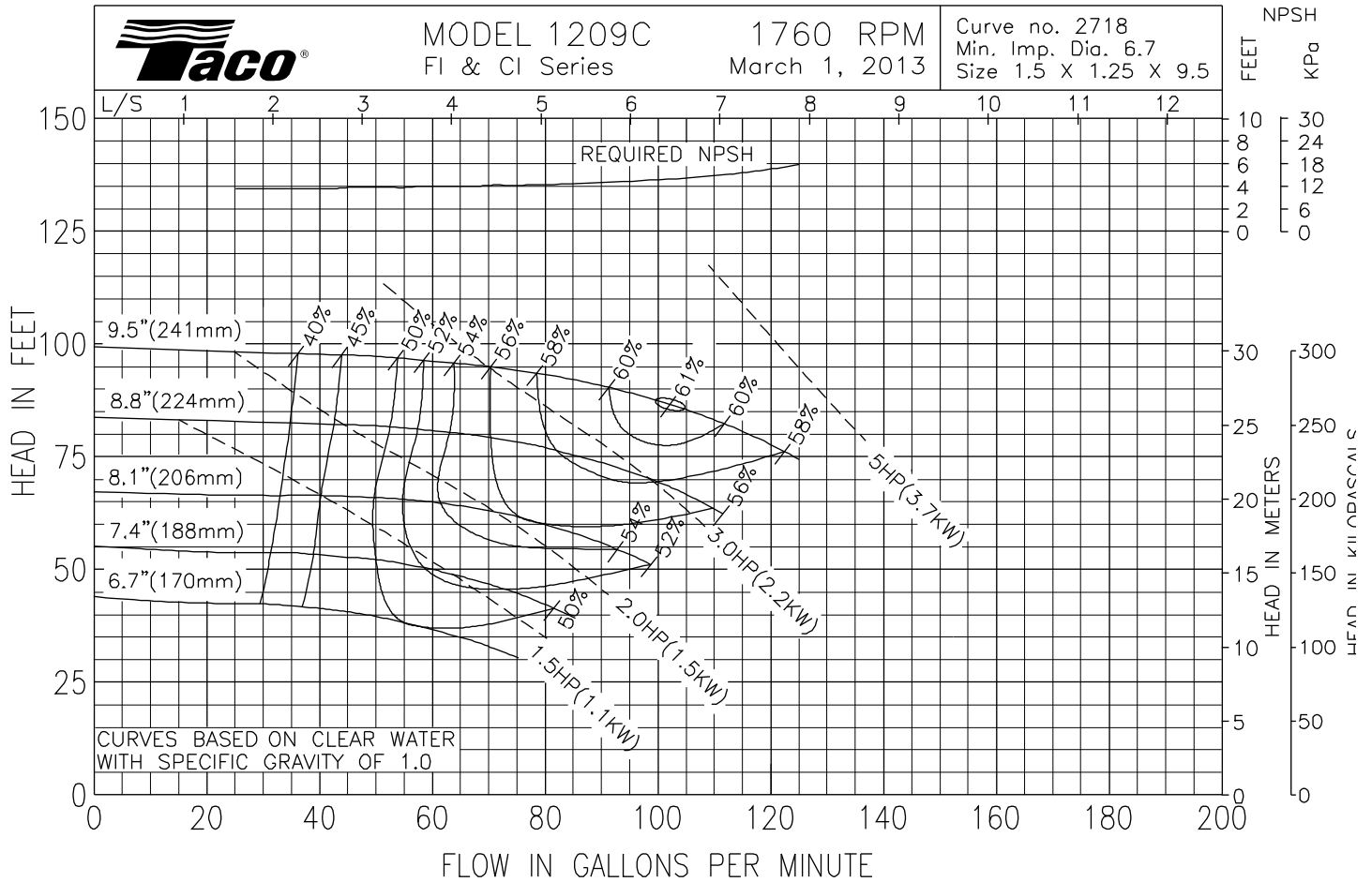

Comments _____

Taco Comfort Solutions™ A Taco Group Company
 Taco, Inc., 1160 Cranston Street, Cranston, RI 02920 | Tel: (401) 942-8000 | FAX: (401) 942-2360
 Taco (Canada), Ltd., 8450 Lawson Road, Suite #3, Milton, Ontario L9T 0J8 | Tel: (905) 564-9422 | FAX: (905) 564-9436
 Visit our web site: www.TacoComfort.com | Printed in USA | ©2015 Taco, Inc.

